

# USER MANUAL

MODEL NUMBER:  
H1-(5-15)-E0



Warning notices: Before using this product, please read this manual carefully and keep it for future reference. The design and specifications are subject to change without prior notice for product improvement. Consult with your dealer or manufacturer for details. The diagram above is just for reference. Please take the appearance of the actual product as the standard.

## THANK YOU LETTER

Thank you for choosing Midea! Before using your new Midea product, please read this manual thoroughly to ensure that you know how to operate the features and functions that your new appliance offers in a safe way.

## CONTENTS

|  |    |
|--|----|
| THANK YOU LETTER .....                           | 01 |
| SAFETY INSTRUCTIONS .....                        | 02 |
| PRODUCT INTRODUCTION .....                       | 06 |
| PRODUCT INSTALLATION .....                       | 10 |
| ELECTRICAL CONNECTION .....                      | 17 |
| COMMISSIONING .....                              | 21 |
| TROUBLE SHOOTING AND MAINTENANCE .....           | 23 |
| TECHNICAL PARAMETERS .....                       | 26 |
| TRADEMARKS, COPYRIGHTS AND LEGAL STATEMENT ..... | 28 |
| DISPOSAL AND RECYCLING .....                     | 28 |
| DATA PROTECTION NOTICE .....                     | 29 |



# SAFETY PRECAUTIONS

## Outline

It describes the assembly, installation, commissioning, maintenance and failure of the energy storage system. Please read it carefully before operating.

## Target Group

This document is intended for professional electrical engineers who are responsible for battery installation and commissioning, including technical support engineers, system engineers, and electrical engineers.

## Symbols Used

In order to ensure the personal and property safety of users when using this product, as well as the efficient use of this product, the manual provides relevant safe operation information and highlights it with corresponding symbols. These stressed messages must be fully understood and absolutely adhered to avoid personal injury and property damage. The symbols used in this manual are listed below.

### **DANGER**

“Danger” indicates a hazardous situation which, if not avoided, will result in death or serious injury.

### **WARNING**

“Warning” indicates a hazardous situation which, if not avoided, could result in death or serious injury.

### **CAUTION**

“Caution” indicates a hazardous situation which, if not avoided, could result in minor or moderate injury.

### **ATTENTION**

“Attention” indicates there are potential risks, if fail to prevent, may lead to equipment cannot normally or property damage.

### **NOTE**

“Note” provides additional information and tips that are valuable for the optimal operation of the product, will help you to solve a problem or save your time.

Please read the instruction carefully. Faulty operation may cause serious injury or death.

### 1.1 Requirement for Installation and Maintenance

The installation of the energy storage system must be in full compliance with national and local laws and regulations.

Read and understand all instructions contained in this manual and familiarize yourself with safety symbols before installing and commissioning the device.

For any maintenance or repair, please contact the nearest authorized repair center. For information about the nearest authorization center, contact your reseller. Do not repair by yourself, which may cause personal injury or property injury.

Before installing and maintaining the device, disconnect the device from the external device using the DC switch. Otherwise, the high voltage may cause serious injury.

#### Installation and Maintenance Personnel Requirements

The personnel responsible for installation and maintenance of the equipment for the first voyage must first receive strict training, understand various safety precautions and master correct operation methods.

- Only qualified professionals or trained personnel are allowed to install, operate, and maintain the device.
- Only qualified professionals are allowed to remove safety facilities and repair devices.
- The personnel, including the operators, trained personnel, and professional personnel, who operate the equipment should have the special operation qualification required by the local state, such as the qualification of high voltage operation, height climbing, and special equipment operation.
- Only professional or authorized personnel can replace equipment or components (including software).

#### NOTE

- Professional personnel: those who have the training or operation experience of equipment and are able to understand the potential sources and magnitude of hazards in the process of equipment installation, operation and maintenance.
- Trained personnel: personnel who have received the appropriate technical training and have the necessary experience are aware of the risks that may be posed to them in performing a certain operation and can take measures to minimize the risks to themselves or other personnel.
- Operators: operators who may have access to the equipment except trained and professional personnel.

## **Transportation Requirement**

The batteries are in the good electrical and physical condition when they ship out from factory. During transport, the energy storage module must be placed in its original package or other proper package. Transportation Company should be responsible for any damage during transport period. Please check the battery thoroughly when taking delivery. If you find any packing problems that may cause the damage of battery or any visible damage, please notice the responsible transportation company immediately. You can ask your installer for help is necessary.

This product contains energy storage module through UN38.3, belongs to the ninth category of dangerous goods. Therefore, loading and unloading must comply with local laws and regulations and industry standards during transportation. Rough loading and unloading may cause short circuit or damage to batteries in containers, which may result in battery leakage, breakage, explosion, or fire.

## 1.2 Description of Safety Information Symbols

### DANGER





High voltage of the product may be harmful to health! Only certified engineer can operate the product; Juveniles, Disable, should not use this product; Keep this product out of the reach of children;

### ATTENTION

The product should be grounded in accordance to the requirements of the local electrical grid company.

### Sings on the Product

The product carries a number of safety related labels. Make sure to read and understand the labels carefully before installing the device.

| Symbols   | Name                                       | Description  |
|---|--|--|
|   | This is a residual voltage in the product  | There is a high voltage, when the product is powered on. After the product is powered off, the internal capacitor is still charged, operator should wait for 5 minutes to ensure the capacitor is completely discharged. |
|  | Caution of high voltage and electric shock | The product operates at high voltages. Prior to performing any work on the product, disconnect the product from voltage sources. All work on the product must be carried out by qualified persons only.                  |
|  | Caution of hot surface                     | The product can get hot during operation. Avoid contact during operation.  |
|  | Grounding Terminal                         | Connect the product to the ground bar for grounding protection   |
|  | Observe the documentation                  | Read all documentation supplied with the product before install  |

# PRODUCT INTRODUCTION

The energy storage system is mainly composed of energy storage module and bidirectional DC/DC unit. The input and output voltages are high DC voltage. The system adopts modular design and stacked installation method. The capacity can be flexibly configured based on actual requirements. The capacity ranges is 5kWh ~ 15kWh.

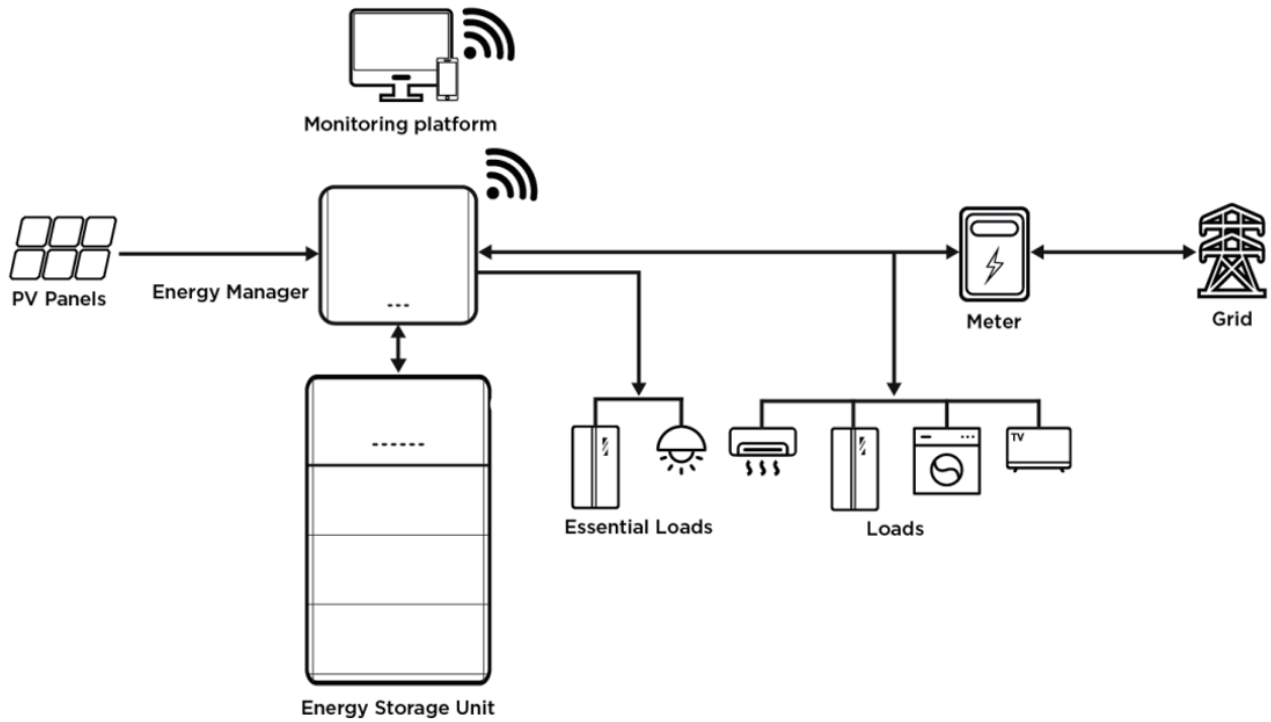

Figure.2-1 Energy storage system application principle diagram

## 2.2 Product Appearance

### System appearance

Front surface

Back surface

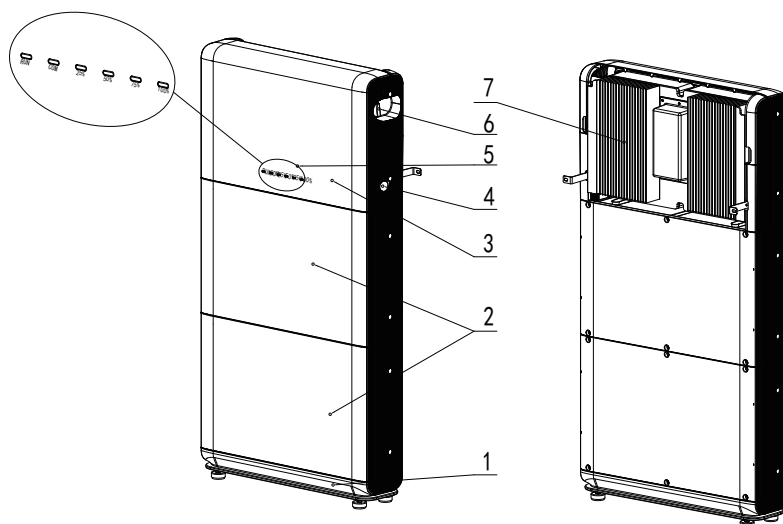



|   |                          |   |                       |
|---|--------------------------|---|-----------------------|
| 1 | Base                     | 2 | Energy storage module |
| 3 | Bidirectional DC/DC unit | 4 | Side cover            |
| 5 | LED indicator            | 6 | DC switch             |
| 7 | Heat sink                |   |                       |

### Bidirectional DC/DC unit appearance

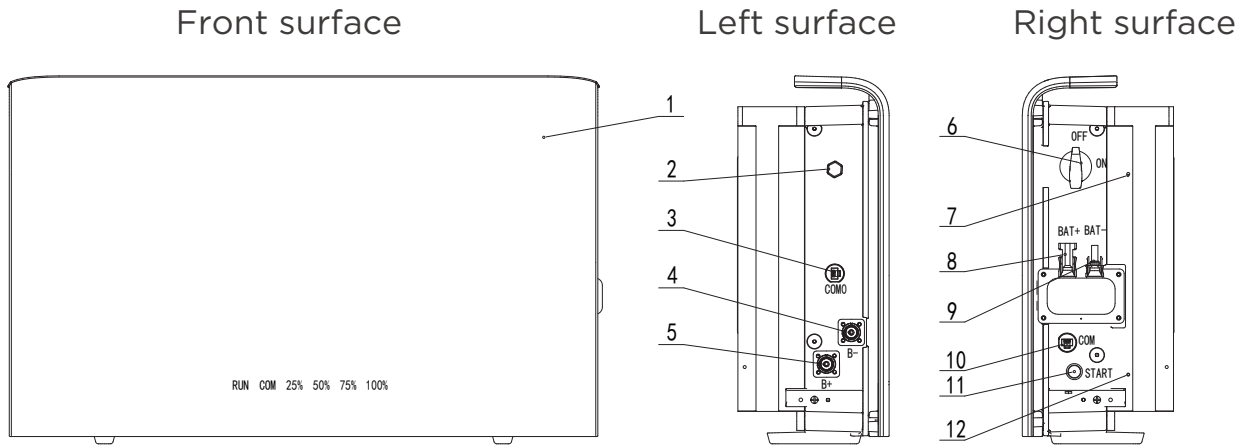

|    |                            |    |                            |
|----|----------------------------|----|----------------------------|
| 1  | Bidirectional DC/DC unit   | 2  | Ventilation valve          |
| 3  | Input communications port  | 4  | BAT cascading terminal(B-) |
| 5  | BAT cascading terminal(B+) | 6  | DC switch                  |
| 7  | Grounding hole             | 8  | BAT output terminal(BAT+)  |
| 9  | BAT output terminal(BAT-)  | 10 | Output communications port |
| 11 | Black startup switch       | 12 | Grounding hole             |

### Energy storage module appearance

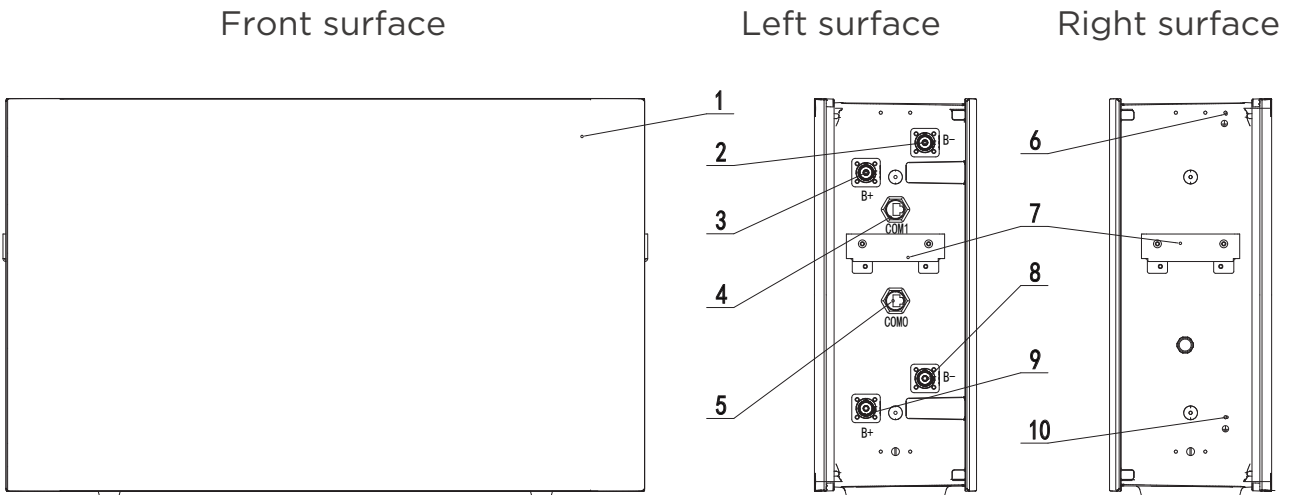

|   |                            |    |                            |
|---|----------------------------|----|----------------------------|
| 1 | Energy storage module      | 2  | BAT cascading terminal(B-) |
| 3 | BAT cascading terminal(B+) | 4  | Output communications port |
| 5 | Input Communications port  | 6  | Grounding hole             |
| 7 | Side handle                | 8  | BAT cascading terminal(B-) |
| 9 | BAT cascading terminal(B+) | 10 | Grounding hole             |

### 2.3 Indicator lights description

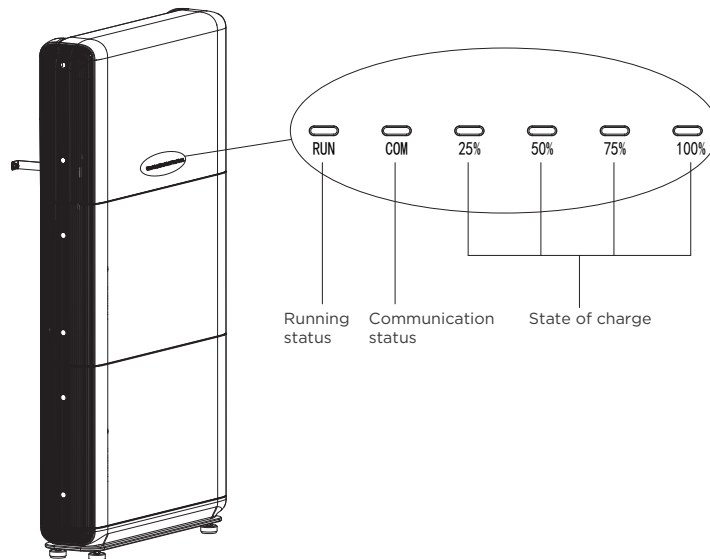
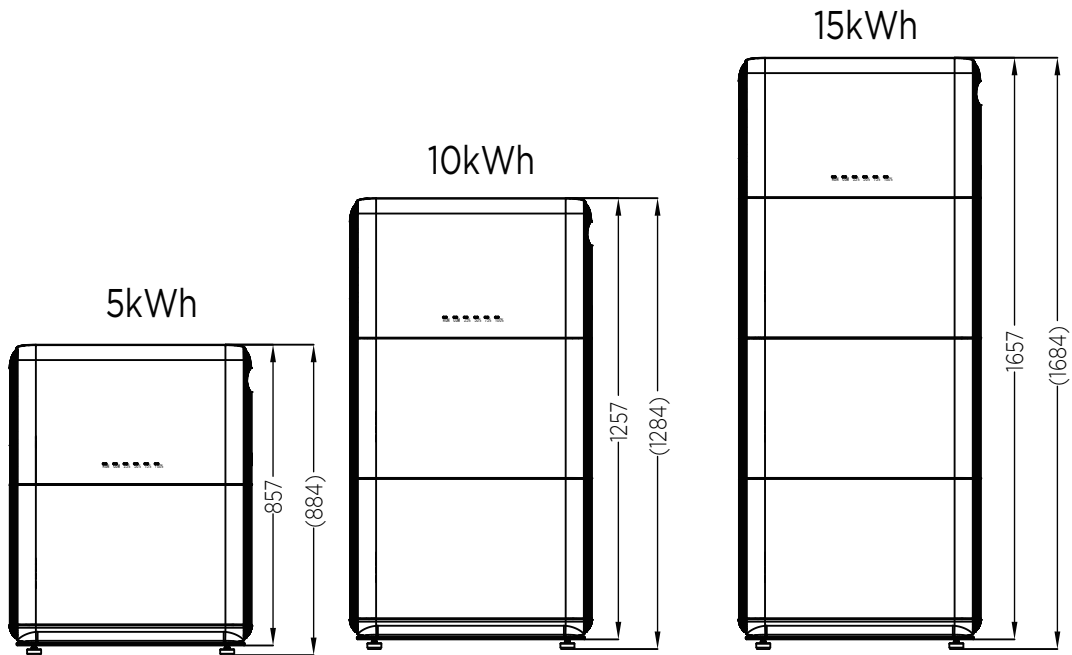

Table 2-1 LED flashing definition

| INDICATOR            | COLOR | STATUS   | EXPLANATION                              |
|----------------------|-------|--|--|
| RUN                  | Green | Steady on  | System is power-on                       |
|                      | Red   | Steady on  | Fault                                    |
|                      | -     | Off  | System is power-off                      |
| COM                  | Green | Steady on  | Communication is normal                  |
|                      | Green | Blinking at long intervals (on for 0.2s and then off for 0.2s) | No communication with BMS                |
|                      | Green | Blinking at long intervals (on for 1s and then off for 1s)     | System is power-on                       |
|                      | -     | Off  | No communication with inverter and BMS   |
| 25%/50%<br>/75%/100% | Green | Steady on  | Battery level is in this range           |
|                      | Green | Blinking at long intervals (on for 0.2s and then off for 0.2s) | Battery is discharging in this range     |
|                      | Green | Blinking at long intervals (on for 1s and then off for 1s)     | Battery is charging in this range        |
|                      | -     | Off  | Battery level has not reached this range |

## 2.4 System capacity expansion description

The energy storage system supports capacity expansion. Up to three battery modules are managed by one power module. The expandable capacity of the single-cluster battery system ranges is 5kWh ~ 15kWh.



# PRODUCT INSTALLATION

## **⚠ DANGER**

Do not install batteries on flammable materials. Do not install batteries in places where flammable or explosive materials are stored.

## **⚠ CAUTION**

The enclosures and fins are very hot when bidirectional DC/DC unit is operated, so do not install energy storage systems where you may inadvertently come into contact with them.

## **ATTENTION**

Consider the weight of the energy storage module when transporting and moving it. Select suitable mounting position and surface. At least two persons are required to install energy storage modules.

## **Checking Before Installation**



### **Checking Outer Packing Materials**

Packing materials and parts can be damaged in transit. Therefore, check the packing materials of the product before installing them. Check whether the outer packing materials are damaged, such as holes and cracks. If any damage is found, please do not open the package and contact the distributor as soon as possible. It is recommended that you remove packing materials within 24 hours before installation.

### **Checking Packing List**

After the energy storage modules and bidirectional DC/DC unit are unpacked, check whether the packaging and accessories are intact. If any damage is found or any components are missing, contact the distributor.

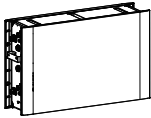
Table 3-1 Components and mechanical parts to be delivered for energy storage modules

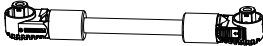
| No | Pictures  | Description                    | Quantity |
|----|---|--------------------------------|----------|
| 1  |  | Energy storage module          | 1pcs     |
| 2  |  | Protective cover               | 2pcs     |
| 3  |  | Battery power cable B+ (Red)   | 1pcs     |
| 4  |  | Battery power cable B- (Black) | 1pcs     |













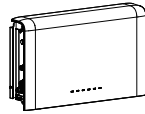
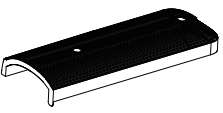
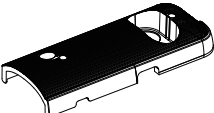

| No | Pictures  | Description                 | Quantity |
|----|---|-----------------------------|----------|
| 5  |  | Battery communication cable | 1pcs     |
| 6  |  | Side connector              | 2pcs     |
| 7  |  | SEM screws M4*10            | 12pcs    |
| 8  |  | Ground cable                | 1pcs     |
| 9  |  | Warranty card               | 1pcs     |
| 10 |   | Quality certificate         | 1pcs     |
| 11 |   | Packing list                | 1pcs     |

Table 3-2 Components and mechanical parts to be delivered for bidirectional DC/DC unit

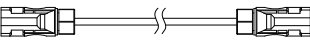
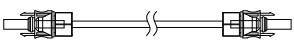
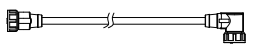
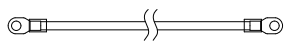

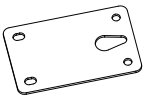

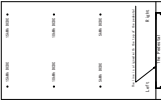
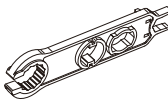
| No | Pictures  | Description                      | Quantity |
|----|---|----------------------------------|----------|
| 1  |    | Bidirectional DC/DC unit         | 1pcs     |
| 2  |  | Left protective cover            | 1pcs     |
| 3  |  | Right protective cover           | 1pcs     |
| 4  |  | Base                             | 1pcs     |
| 5  |  | Heavy duty leveling screw leg    | 4pcs     |
| 6  |  | base protective cover            | 2pcs     |
| 7  |  | Battery power cable BAT+ (Red)   | 1pcs     |
| 8  |  | Battery power cable BAT- (Black) | 1pcs     |
| 9  |  | Battery communication cable      | 1pcs     |
| 10 |  | Ground cable                     | 1pcs     |
| 11 |  | SEM screw M4*10                  | 12pcs    |
| 12 |  | Expansion bolt M6*60             | 2pcs     |

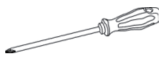
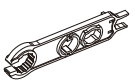

|    |   |                            |      |
|----|---|----------------------------|------|
| 13 |  | Side connector             | 2pcs |
| 14 |  | Anti-tip bracket           | 2pcs |
| 15 |  | Marking-off template       | 1pcs |
| 16 |  | D4 Disassembly tool        | 1pcs |
| 17 |  | Quick guide                | 1pcs |
| 18 |   | Packing list               | 1pcs |
| 19 |   | User manual                | 1pcs |
| 20 |   | Delivery inspection report | 1pcs |
| 21 |   | Quality certificate        | 1pcs |
| 22 |   | Warranty card              | 1pcs |

### 3.2 Preparation for Installation Tools

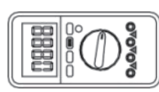
Prepare tools for installation and electrical connections.

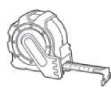
Table 3-3 Tools required for installation and electrical connections

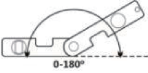
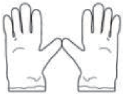
| NO | Tool  | Model  | Function   |
|----|---|--|--|
| 1  |  | Hammer drill<br>Recommend Drill @<br>Φ8mm          | Used to drill holes on the wall  |
| 2  |  | 4mm<br>Screw driver                                | Remove and install screws and wires  |
| 3  |  | D4 Disassembly tool<br>(Provided with the product) | Remove the output terminal of the bidirectional DC/DC unit and inverter  |
| 4  |  | Sleeve   | Install fixed support rack   |
| 5  |  | Multi meter  | Check whether the cable connection is correct, the positive and negative terminals of the battery are correct, and the grounding is reliable |
| 6  |  | Marker   | Mark signs   |
| 7  |  | Measuring tape                                     | Measure distance   |

|    |   |               |  |
|----|---|---------------|--|
| 8  |  | Level         | Ensure that the base is level          |
| 9  |  | ESD gloves    | Installer wear when installing product |
| 10 |  | Safety goggle | Installer wear when drill holes        |
| 11 |  | Mask          | Installer wear when drill holes        |

### 3.3 Installation Environment

Before installation, determine the proper position for installing the energy storage system. The following requirements must be met:

- Choose a dry, clean, neat and convenient location for installation.
- Machine ambient temperature:  $-10\sim 50^{\circ}\text{C}$ .
- Relative humidity: 5-95% (non-condensing).
- The product should be placed in a well-ventilated place.
- There are no inflammable and explosive objects near the installation position of the product.
- The highest altitude of the installation environment is 2000m.

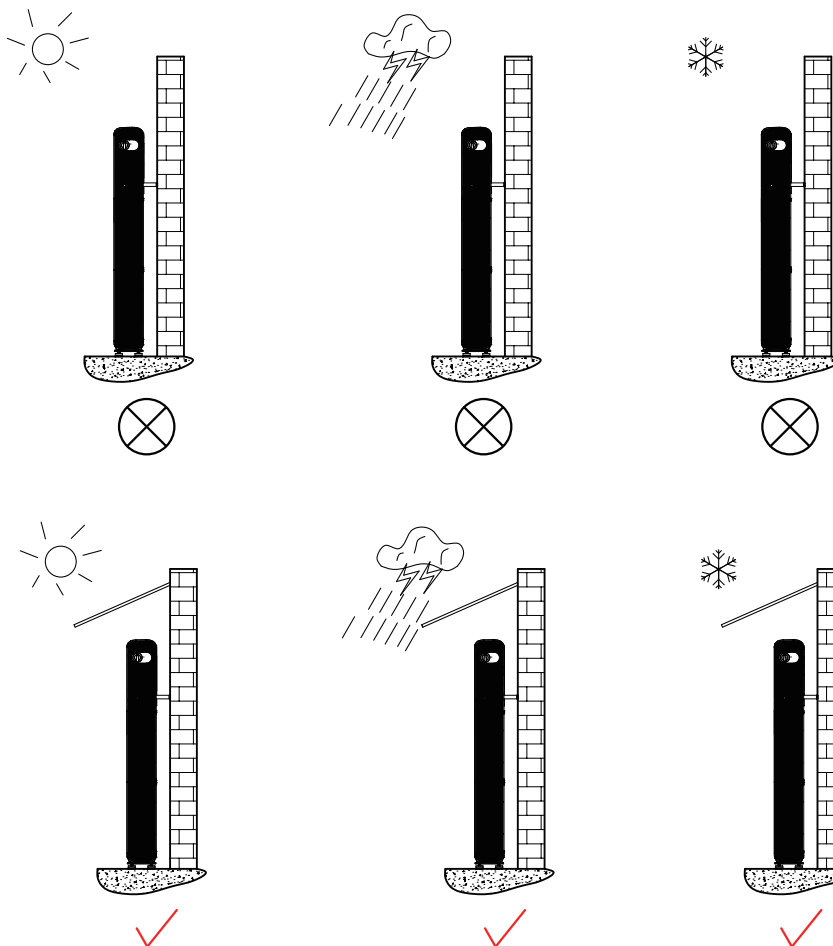

### 3.4 Installation Space

To ensure sufficient space for installation and heat dissipation, reserve enough space around the energy storage system. The requirements are as follows:

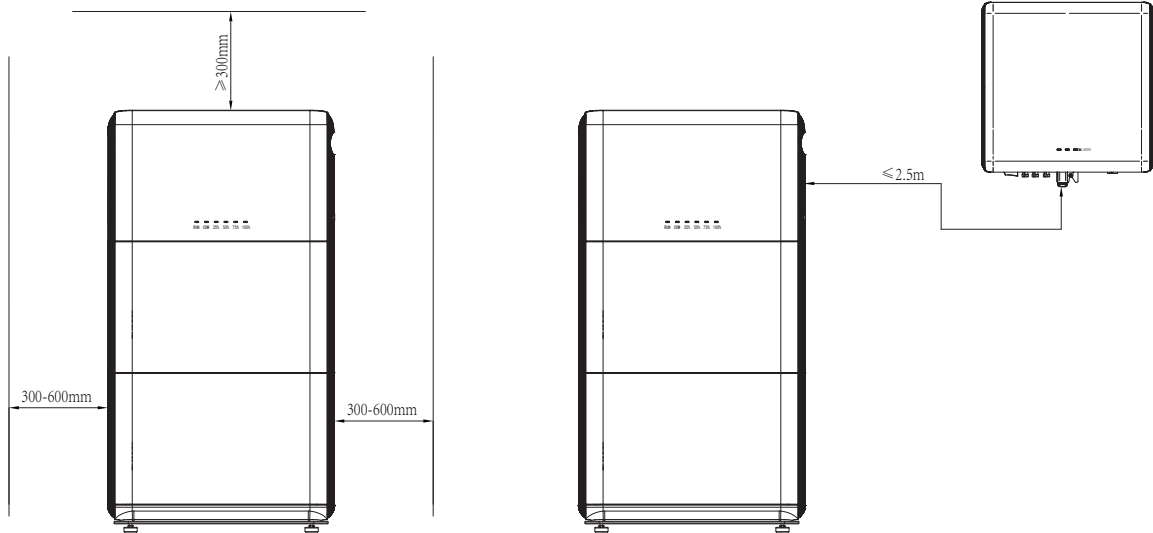

### 3.5 Energy Storage System Installation

#### Step1: Base installation

Install the four foot cups under the base, align the base with the wall, and ensure that the base is 77mm~92mm away from the wall surface. Adjust the four foot cups of the base until it is level.

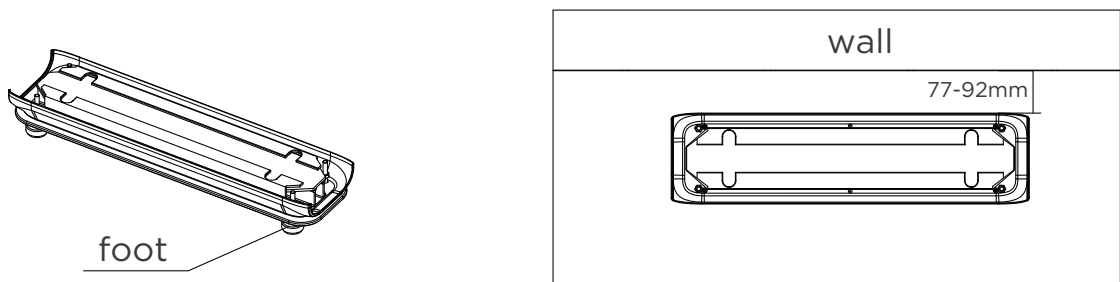

Figure. 3-1 base installation diagram

#### Step 2: Installing expansion bolts

Align the bottom edge of the marking-off template with the surface of the base, determine the drilling hole positions on the wall for securing the bidirectional DC/DC unit, and mark the positions using a marker.

#### NOTE

The expansion bolts delivered with the battery are mainly used for solid concrete walls. If other types of walls are used, ensure that the walls meet the loadbearing requirements (one energy storage module weighs 52kg) and select the bolts by yourself.



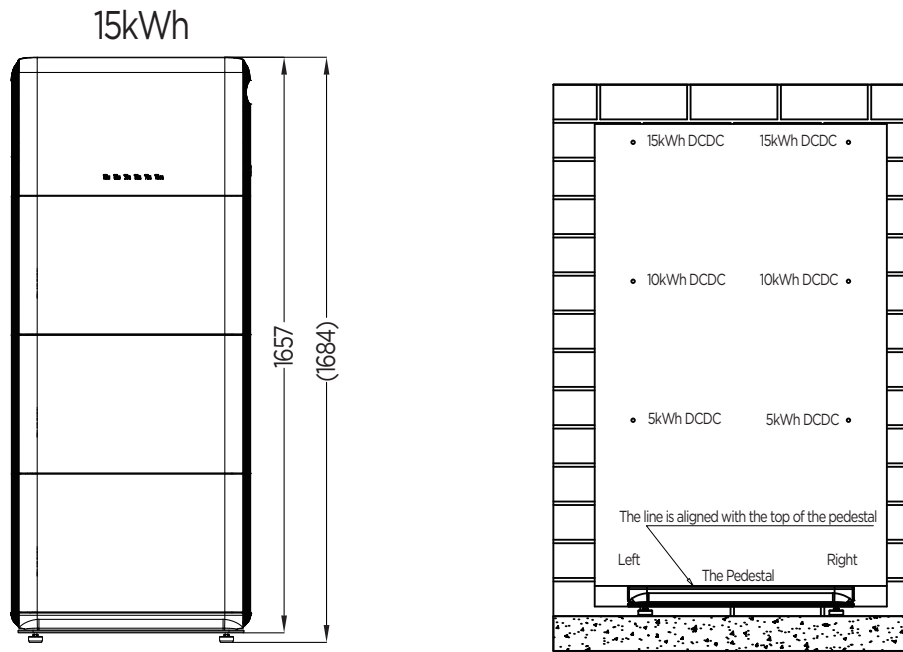

Figure. 3-2 Mounting hole dimensions

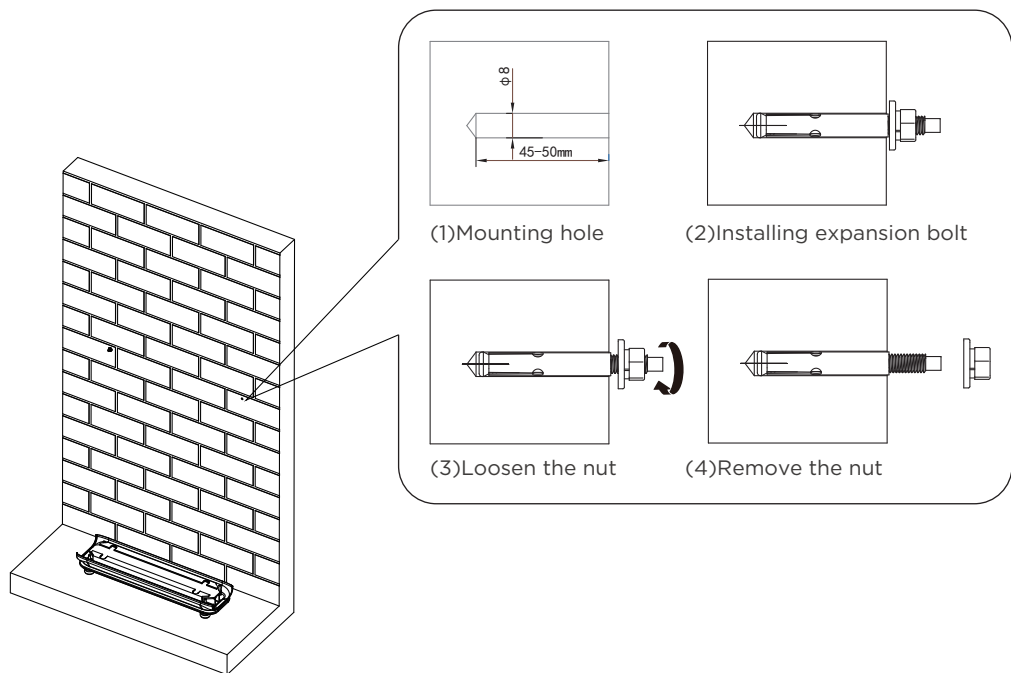
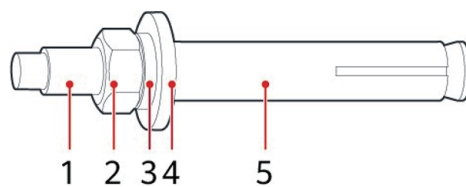

Figure.3-3 Expansion bolts installation diagram



(1) Bolt (2) Nut (3) Spring washer (4) Flat washer (5) Expansion sleeve

Figure.3-4 M6 expansion bolt structure diagram

### Step 3: Installing the energy storage modules and bidirectional DC/DC unit

Align the first energy storage module on the base, install the connectors on both sides, and tighten the 8 screws on both sides. Install the remaining energy storage modules and bidirectional DC/DC unit from bottom to top.

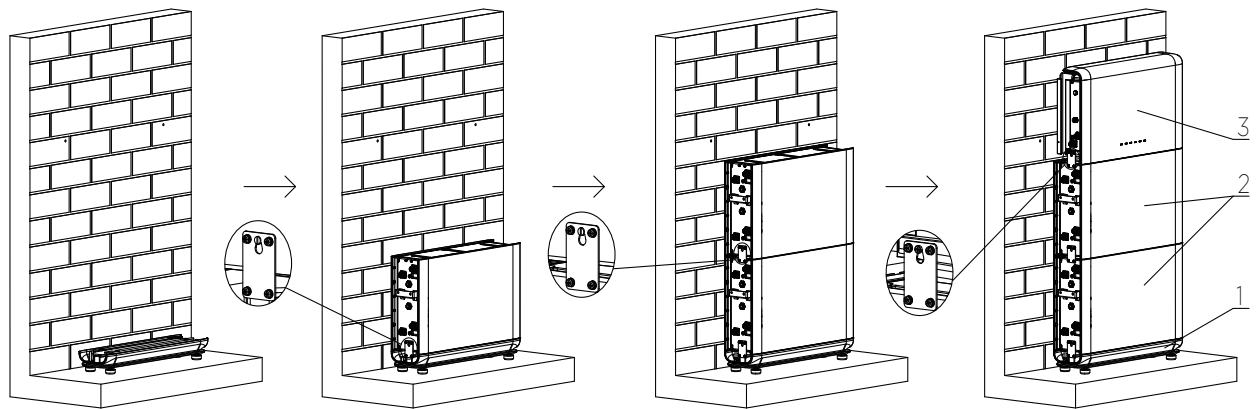

1-Base      2-Energy storage module      3-Bidirectional DC/DC unit

Figure.3-5 Installing the energy storage and bidirectional DC/DC unit diagram

### Step 4: Anti-tip bracket installation

Secure the bidirectional DC/DC unit to the wall.

#### **⚠ WARNING**

The bidirectional DC/DC unit must be fixed on the wall.

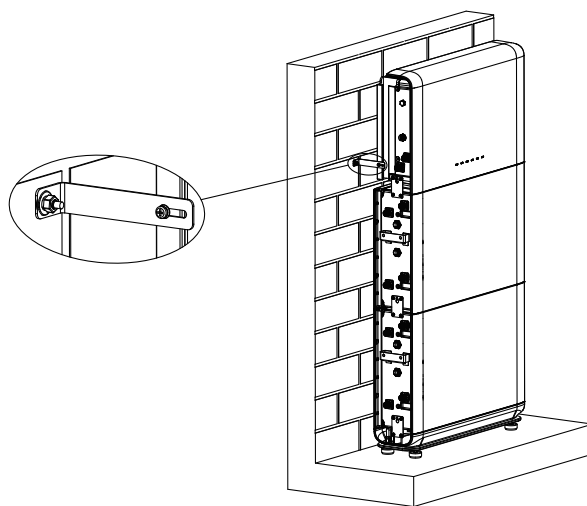

Figure.3-6 Installing the Anti-tip bracket diagram

# ELECTRICAL CONNECTION

This product is used for battery energy storage PV system. Equipment can be damaged if not used as intended.

## ATTENTION

Only professional electrical engineers can install and maintain batteries. When making electrical connections, wear rubber gloves and protective clothing. When connecting the device electrically, you must first connect the protection ground cable. When removing a device, ensure that the PGND cable is removed at last.

## ⚠ DANGER

Before electrical connection, ensure that the DC switch of the bidirectional DC/DC unit is OFF, the running status LED is OFF, and the energy storage module has no output voltage.

## 💡 NOTE

The equipment damage caused by operator's wrong wiring is not covered by the product warranty.

### Step1: Protection grounding cable connection

Connect the ground points of modules in sequence, and secure the ground cable using a ground screw.

## ⚠ DANGER

- Connect cables in accordance with local installation laws and regulations.
- Before connecting cables, ensure that the DC switch on the battery and all the switches connected to the battery are set to OFF. Otherwise, the high voltage of the battery may result in electric shocks.

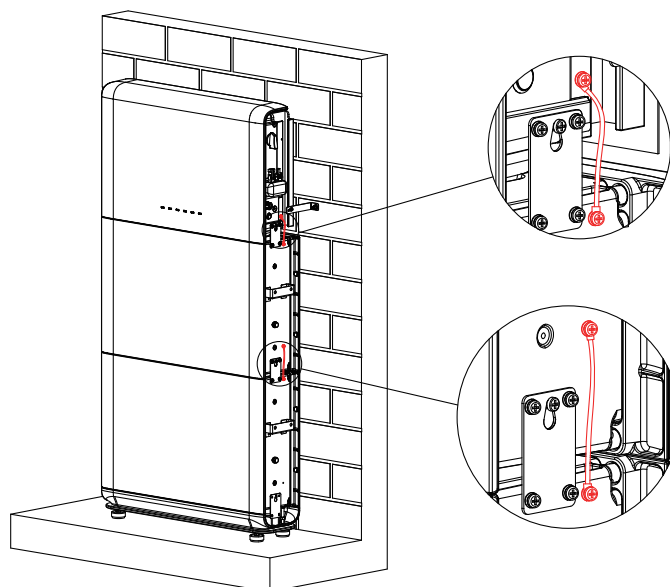

## Step2:Installing internal DC terminals

Insert the positive and negative connectors delivered with the battery into the positive and negative battery cascading terminals (B+ and B-).

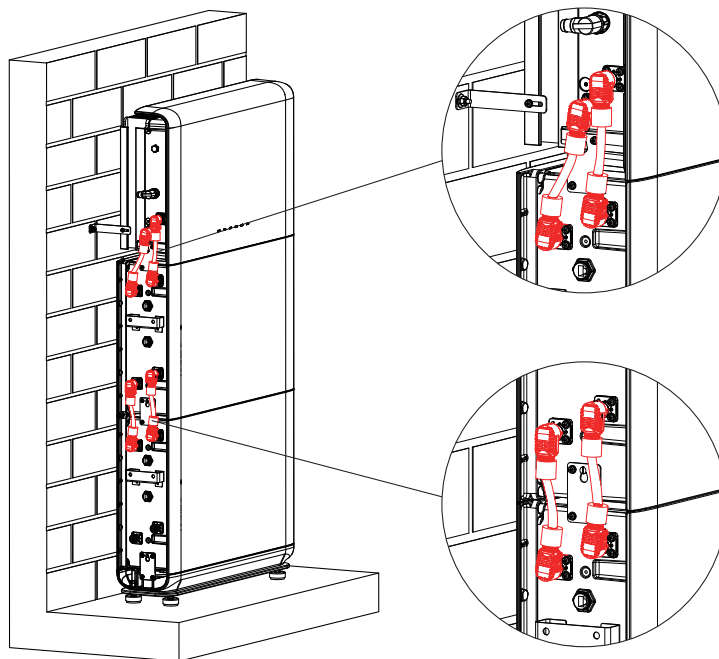

## Step3:Connecting internal communication cables

Connecting communication cables between the bidirectional DC/DC unit (COM0) and energy storage modules (COM1).

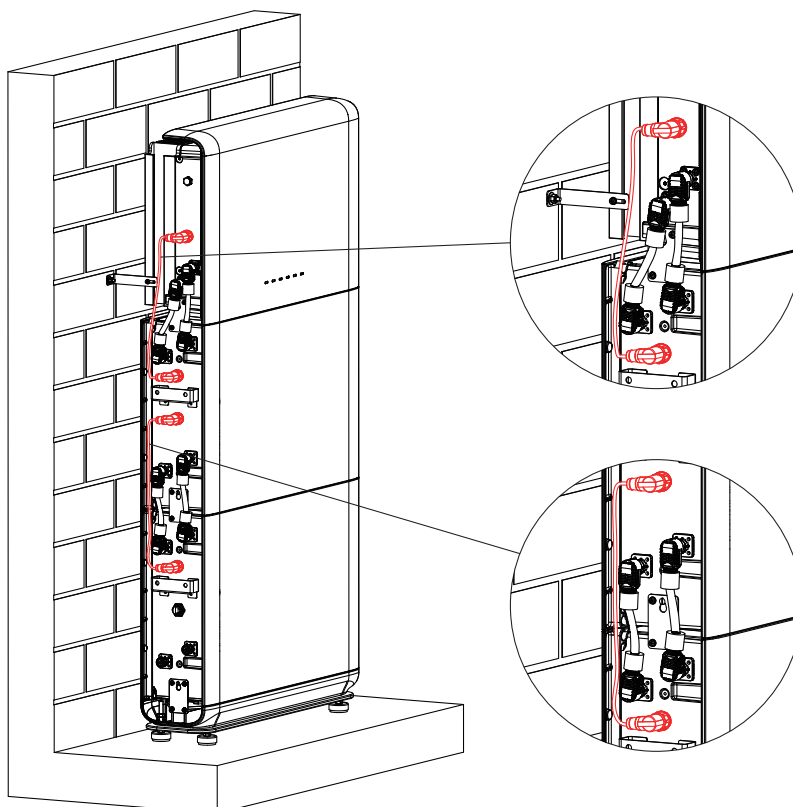

#### Step4: External electrical connection

Connect the bidirectional DC/DC unit Com Terminal to the inverter BMS port for communication between inverter and energy storage system. The following is an example of the storage inverter:

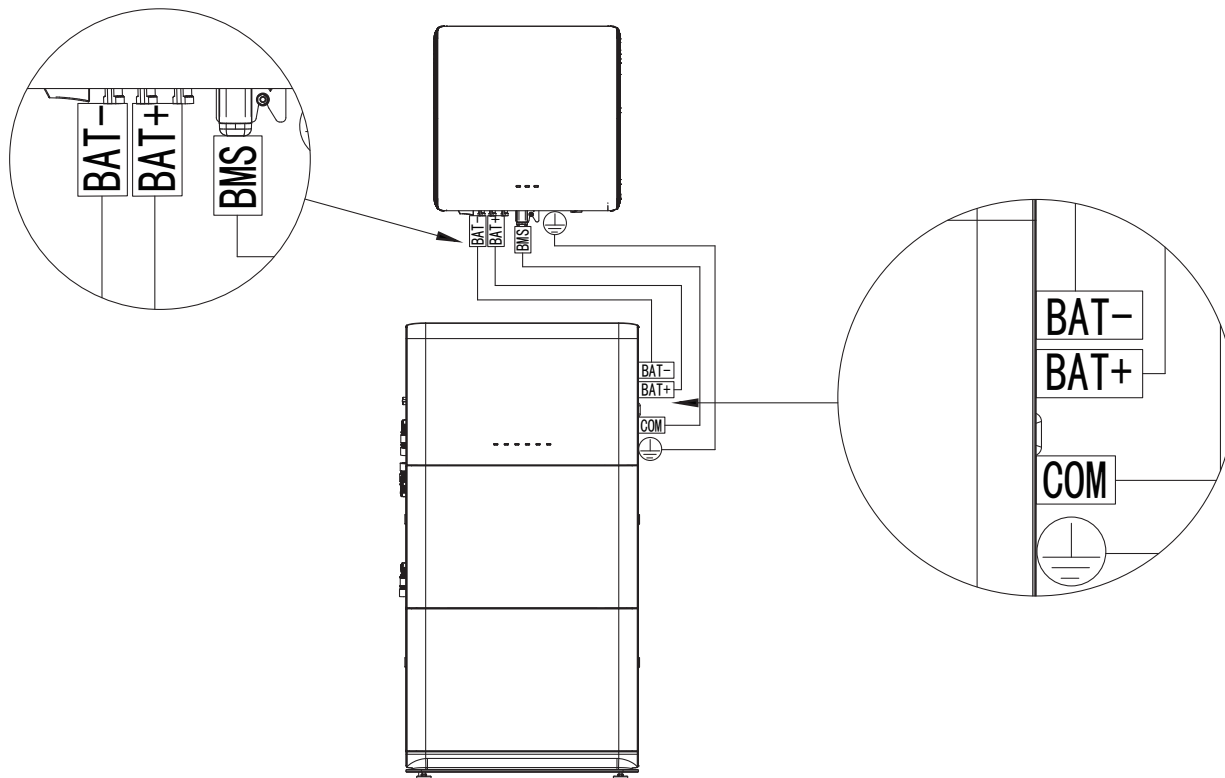

#### Step5: Install the protective cover

After electrical connections are complete and cable connections are correct and reliable, install the external protective cover.

- Install protective covers on both sides of the base.
- Install protective covers on both sides of the energy storage module or bidirectional DC/DC unit.
- Tighten the protective cover with screws.

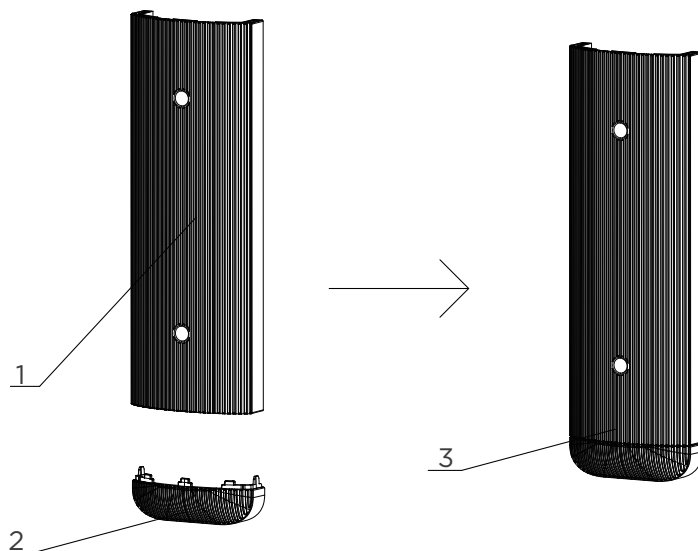

1.Side cover of battery module 2. Side cover of base 3. Side cover assembly

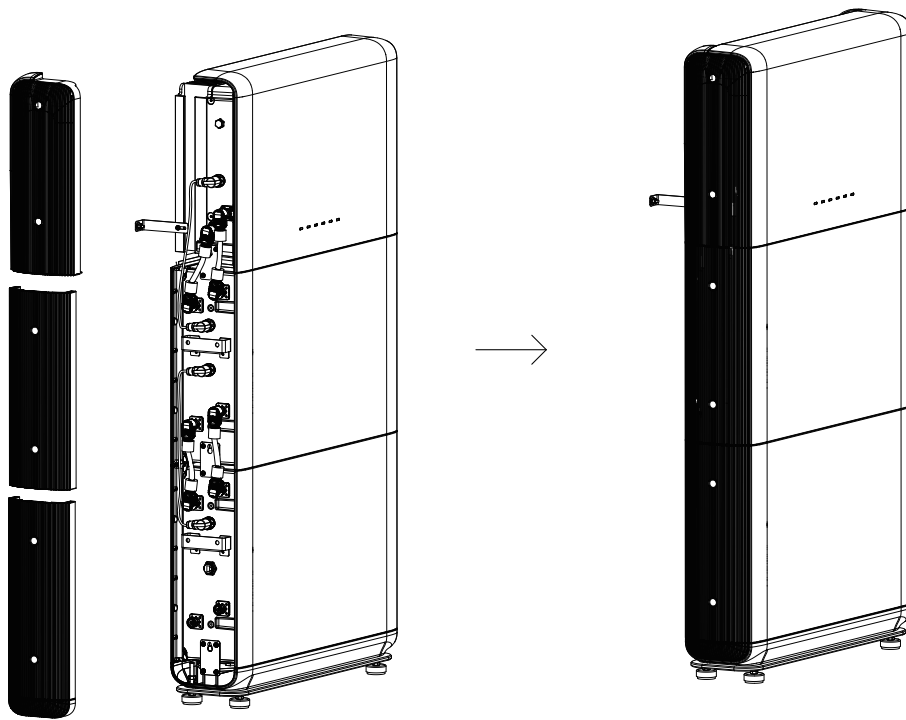

Figure4-1 Diagram of installing left protective cover

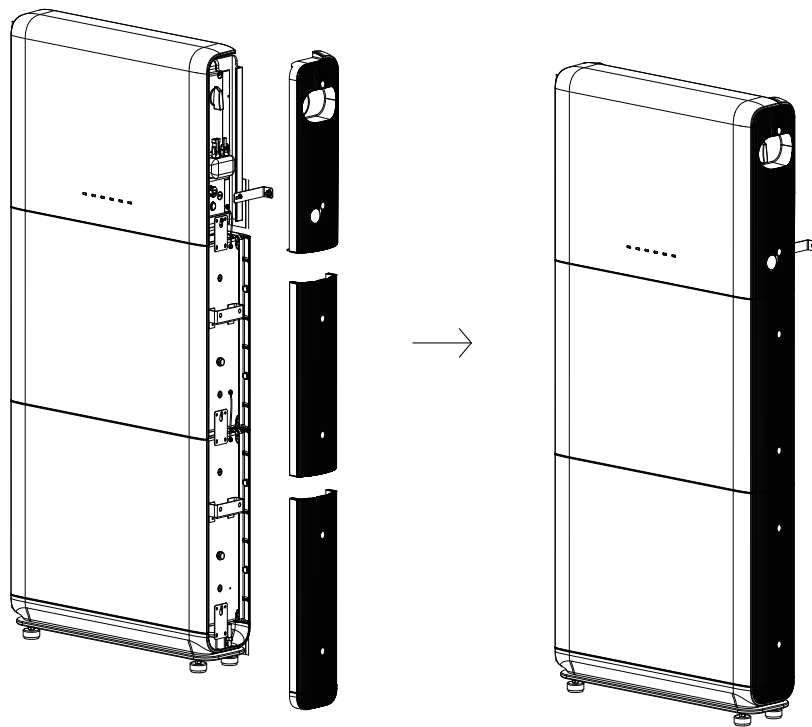

Figure4-2 Diagram of installing right protective cover

# COMMISSIONING

## 5.1 Double Check

Please double check the following items before running:

- Energy storage, bidirectional DC/DC unit and the base should be completely fixed. Each BAT+/BAT- line is firmly connected, the polarity is correct, and the voltage is in line with the accessible range.
- The DC switch of the bidirectional DC/DC unit is OFF, and the running status LED indicator is OFF.
- Ensure that the communication cable is firmly connected to the terminal resistor.
- Install sealing plugs on unused terminals or interfaces.
- Cable is arranged reasonably, and the cable is tidy and without damage.

## 5.2 Electrify for the First Time

- Set the DC switch of the bidirectional DC/DC unit to ON.
- Press the black start switch on the bidirectional DC/DC unit to power on the battery more than 10s. Observe the LED indicator on the bidirectional DC/DC unit to check the SOC LED indicator flashing.

## 5.3 Battery Powered Off

- Press the black start switch of bidirectional DC/DC unit for 30s.
- Set the DC switch of the bidirectional DC/DC unit to OFF. All the LED indicators on the bidirectional DC/DC unit are OFF. After the system is powered OFF for five minutes, ensure that the remaining battery charges are discharged before performing maintenance.

## 5.4 Black Start up (general)

### NOTE

When the battery SOC is 0%, the battery cannot be activated by holding the black start button. The battery can be started only after both the DC and AC power supplies are connected

It is recommended that the battery be charged to 50% SOC. Long-term storage will cause capacity loss, after a lithium battery is stored for 12 months in the recommended storage temperature, the irreversible capacity loss rate is 3%–10%.

Step 1 Connect power cables and communications cables correctly.

Step 2 Turn the DC switch on the bidirectional DC/DC unit to ON.

Step 3 Turn the AC switch between the inverter and the grid to ON.

Step 4 Turn the PV switch between the inverter and the PV panels to ON.

Step 5 Hold down the black start button for about 4s to activate the battery. The running status LED indicator turns and keeps green. The battery comprehensive LED shows the battery SOC value. Once any LED above is lighted, release the button.

Step 6 Hold down the black start button again for about 5s and release to start the system.

Step 7 Confirm the start-up begins by blink of any battery comprehensive LED.

 **NOTE**

If the black start-up fails, the running status LED indicator turns and keeps red. Follow the next steps.

Step f1 Turn the AC switch between the inverter and the grid to OFF.

Step f2 Turn the PV switch between the inverter and the PV panels to OFF.

Step f3 Turn the DC switch on the battery power module to OFF.

Step f4 Hold down the black start button for about 34s to deactivate the battery.

Once all LED indicators on the bidirectional DC/DC unit turn dark, release the button.

Step f5 Turn to follow step 1 to step 7.



# TROUBLE SHOOTING AND MAINTENANCE

## 6.1 Troubleshooting

This section describes the potential errors for this product. Please read carefully for the following tips when doing the troubleshooting:

### Alarm severities are defined as follows

**Major:** The inverter is faulty. As a result, the output power decreases or the grid-tied power generation is stopped.

**Minor:** Some components are faulty without affecting the grid-tied power generation.

Table6-1 List of Reported Faults of APP/Web display

| Alarm ID | Alarm Name                            | Alarm Severity | Possible Cause  | Trouble shooting  |
|----------|---------------------------------------|----------------|---|---|
| 2001     | Power module overtemperature          | Major          | <ol style="list-style-type: none"> <li>1. The installation position of the battery power control module is not well ventilated.</li> <li>2. The ambient temperature is excessively high.</li> <li>3. The battery power control module is abnormal.</li> </ol> | <ol style="list-style-type: none"> <li>1. Check the ventilation and whether the ambient temperature of the power control module exceeds the upper threshold.</li> <li>2. If the ventilation is poor or the ambient temperature is excessively high, improve the ventilation and heat dissipation.</li> <li>3. If the ventilation and ambient temperature are normal, contact your dealer or technical support.</li> </ol>   |
| 2002     | Low battery DC input bus voltage      | Major          | <ol style="list-style-type: none"> <li>1. The DC bus voltage of the battery is low.</li> <li>2. The battery DC switch is OFF.</li> <li>3. The battery cables are not correctly connected.</li> </ol>  | <ol style="list-style-type: none"> <li>1. Turn off the inverter AC output switch, inverter DC input switch, and battery DC switch, and wait for 5 minutes.</li> <li>2. Check the cable connections to the power control module by referring to the quick installation guide.</li> <li>3. After checking that the battery power cables are correctly connected, turn on the battery DC switch, AC output switch, and inverter DC input switch in sequence.</li> <li>4. If the alarm persists, contact your dealer or technical support.</li> </ol> |
| 2003     | Battery expansion module undervoltage | Major          | The voltage of a battery expansion module is low.   | If the sunlight is sufficient or AC reverse charging is allowed, the battery expansion modules can be charged when the inverter is running.   |

## 6.2 Daily Maintenance of the System

To ensure that the battery can operate properly for a long term, you are advised to perform routine maintenance on it as described in this chapter.

### ATTENTION

Before cleaning the system, connecting cables, and ensuring the grounding reliability, power off the system.

| Check Item            | Check Method  | Maintenance Interval  |
|-----------------------|---|---|
| System cleanliness    | Check periodically that the heat sinks are free from obstacles and dust.  | Once every 6 to 12 months   |
| System running status | <ul style="list-style-type: none"> <li>• Check that the battery is not damaged or deformed.</li> <li>• Check that the battery does not generate abnormal sound when it is in operation.</li> <li>• Check that the battery parameters are correctly set when the battery is running.</li> </ul>                                  | Once every 6 months   |
| Electrical connection | <ul style="list-style-type: none"> <li>• Check that cables are secured.</li> <li>• Check that cables are intact, and that in particular, the parts touching the metallic surface are not scratched.</li> <li>• Check that unused DC input terminals, battery terminals, and COM ports are locked by watertight caps.</li> </ul> | The first inspection is 6 months after the initial commissioning. From then on, the interval can be 6 to 12 months. |
| Grounding reliability | <ul style="list-style-type: none"> <li>• Check that ground cables are securely connected.</li> </ul>  | The first inspection is 6 months after the initial commissioning. From then on, the interval can be 6 to 12 months. |

## 6.3 Battery Module Storage Requirements and Power Supply

### Battery Module Storage Requirements:

- Environment temperature: -10°C ~45°C
- Recommended storage temperature: 20°C ~30°C
- Storage relative humidity range: 5%~80%.
- Store in a dry, clean, and ventilated environment, away from direct sunlight.
- When storing the battery module, place it correctly. Do not put the battery module upside down or on its side.
- If the energy storage module is stored for a long time, replenish the power supply periodically.

### Recharge Requirements during Normal Storage

When the battery is stored for a long time, you need to perform regular maintenance. If the storage time is close to that shown in the following table, arrange supplementary power supply in time.

Recharge conditions when in storage

| <b>Storage Environment Temperature</b> | <b>Relative Humidity of Storage Environment</b> | <b>Storage Time</b> | <b>SOC</b>  |
|--|---|---------------------|-------------|
| < -10°C                                | /   | Prohibit            | /           |
| -10 ~ 25°C                             | 5%~ 80%   | ≤ 12 months         | 40%≤SOC≤80% |
| 25~ 35°C                               | 5%~ 80%   | ≤ 6 months          | 40%≤SOC≤80% |
| 35~ 45°C                               | 5%~ 80%   | ≤ 3 months          | 40%≤SOC≤80% |
| > 45°C                                 | /   | Prohibit            | /           |

# TECHNICAL PARAMETERS

| System Parameters                            | H1-5-E0                                    | H1-10-E0        | H1-15-E0        |
|--|--|-----------------|-----------------|
| Number of power modules                      | 1  | 1               | 1               |
| Battery module energy                        | 5kWh                                       | 5kWh            | 5kWh            |
| Number of battery Modules                    | 1  | 2               | 3               |
| Battery usable energy <sup>1</sup>           | 5kWh                                       | 10kWh           | 15kWh           |
| Max. output power                            | 2.5kW                                      | 5kW             | 5kW             |
| Nominal voltage (three phase system)         | 600V                                       |                 |                 |
| Operating voltage range (three phase system) | 600-980V                                   |                 |                 |
| Display                                      | SOC status indicator, LED indicator        |                 |                 |
| Communication                                | RS485                                      |                 |                 |
| Dimension (W*H*D)                            | 690*815*168 mm                             | 690*1223*168 mm | 690*1631*168 mm |
| Weight (Floor stand toolkit included)        | 77.3kg                                     | 129.3kg         | 181.3kg         |
| Installation                                 | Floor stand                                |                 |                 |
| Operating temperature                        | -20°C ~ + 55°C (-4°F ~ 131°F) <sup>3</sup> |                 |                 |
| Max. operating altitude                      | 2000m                                      |                 |                 |
| Environment                                  | Outdoor/ Indoor <sup>4</sup>               |                 |                 |
| Relative humidity                            | 5%~95%                                     |                 |                 |
| Cooling                                      | Natural convection                         |                 |                 |
| Protection rating                            | IP 65                                      |                 |                 |
| Cell technology                              | Lithium-iron phosphate (LiFePO4)           |                 |                 |

| <b>Bidirectional DC/DC Unit</b>             |  |
|---|--|
| Rated charge and discharge power            | 5kW  |
| Nominal voltage                             | 600V   |
| Operating voltage range(three phase system) | 600-980V   |
| Power module dimension (W*H*D)              | 690*407*168mm  |
| Power module weight                         | 25.3kg   |
| Ingress Protection                          | IP65   |
| <b>Energy Storage Module</b>                |  |
| Nominal Voltage                             | 51.2V  |
| Voltage Range                               | 45-57.6V   |
| Max. Continuous Current                     | 50A  |
| Battery usable energy <sup>1</sup>          | 5.12kWh  |
| Battery module dimension (W*H*D)            | 690*408*165mm  |
| Battery module weight                       | 52kg <sup>2</sup>  |
| Ingress Protection                          | IP66   |
| <b>Standard</b>                             |  |
| Certificates                                | IEC/EN 62109-1, EN 61000-6-1, EN 61000-6-3, IEC62619, UN38.3, IEC/EN 62040-1 |

1. Test conditions: 100% depth of discharge(DoD), 0.2C rate charge & discharge at 25°C , at the beginning of life.
2. The weight of the battery module is subject to the actual product, with a tolerance of  $\pm 3\%$ .
3. Refer to battery warranty letter for conditional application.
4. Please follow the user manual during the installation, use, and maintenance of the storage system.

# TRADEMARKS, COPYRIGHTS AND LEGAL STATEMENT

 Midea logo, word marks, trade name, trade dress and all versions thereof are valuable assets of Midea Group and/or its affiliates (“Midea”), to which Midea owns trademarks, copyrights and other intellectual property rights, and all goodwill derived from using any part of an Midea trademark. Use of Midea trademark for commercial purposes without the prior written consent of Midea may constitute trademark infringement or unfair competition in violation of relevant laws.

This manual is created by Midea and Midea reserves all copyrights thereof. No entity or individual may use, duplicate, modify, distribute in whole or in part this manual, or bundle or sell with other products without the prior written consent of Midea.

All the described functions and instructions were up to date at the time of printing this manual. However, the actual product may vary due to improved functions and designs.

## DISPOSAL AND RECYCLING

### **Important instructions for environment(European Disposal Guidelines)**

Compliance with the WEEE Directive and Disposing of the Waster Product:  
This product complies with EU WEEE Directive. This product bears a classification symbol for waster electrical and electronic equipment (WEEE).

This symbol indicates that this product shall not be disposed with other household wastes at the end of its service life. Used device must be returned to official collection point for recycling of electrical electronic devices. To find these collection systems please contact to your local authorities or retailer where the product was purchased. Each household performs important role in recovering and recycling of old appliance. Appropriate disposal of used appliance helps prevent potential negative consequences for the environment and human health.

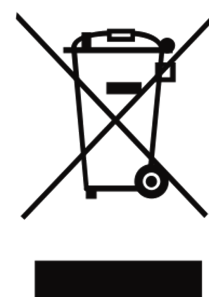

# DATA PROTECTION NOTICE

For the provision of the services agreed with the customer, we agree to comply without restriction with all stipulations of applicable data protection law, in line with agreed countries within which services to the customer will be delivered, as well as, where applicable, the EU General Data Protection Regulation (GDPR).

Generally, our data processing is to fulfil our obligation under contract with you and for product safety reasons, to safeguard your rights in connection with warranty and product registration questions. In some cases, but only if appropriate data protection is ensured, personal data might be transferred to recipients located outside of the European Economic Area.

Further information are provided on request. You can contact our Data Protection Officer via **MideaDPO@midea.com**. To exercise your rights such as right to object your personal data being processed for direct marketing purposes, please contact us via **MideaDPO@midea.com**. To find further information, please follow the QR Code.

The design and specifications are subject to change without prior notice for product improvement. Consult with the sales agency or manufacturer for details. Any updates to the manual will be uploaded to the service website, please check for the latest version.



*make yourself at home*



[www.midea.com](http://www.midea.com)

© Midea 2023 all rights reserved

H1-(5-15)-E0

1611460000021

20230110



